

Section 6:

Parts Data

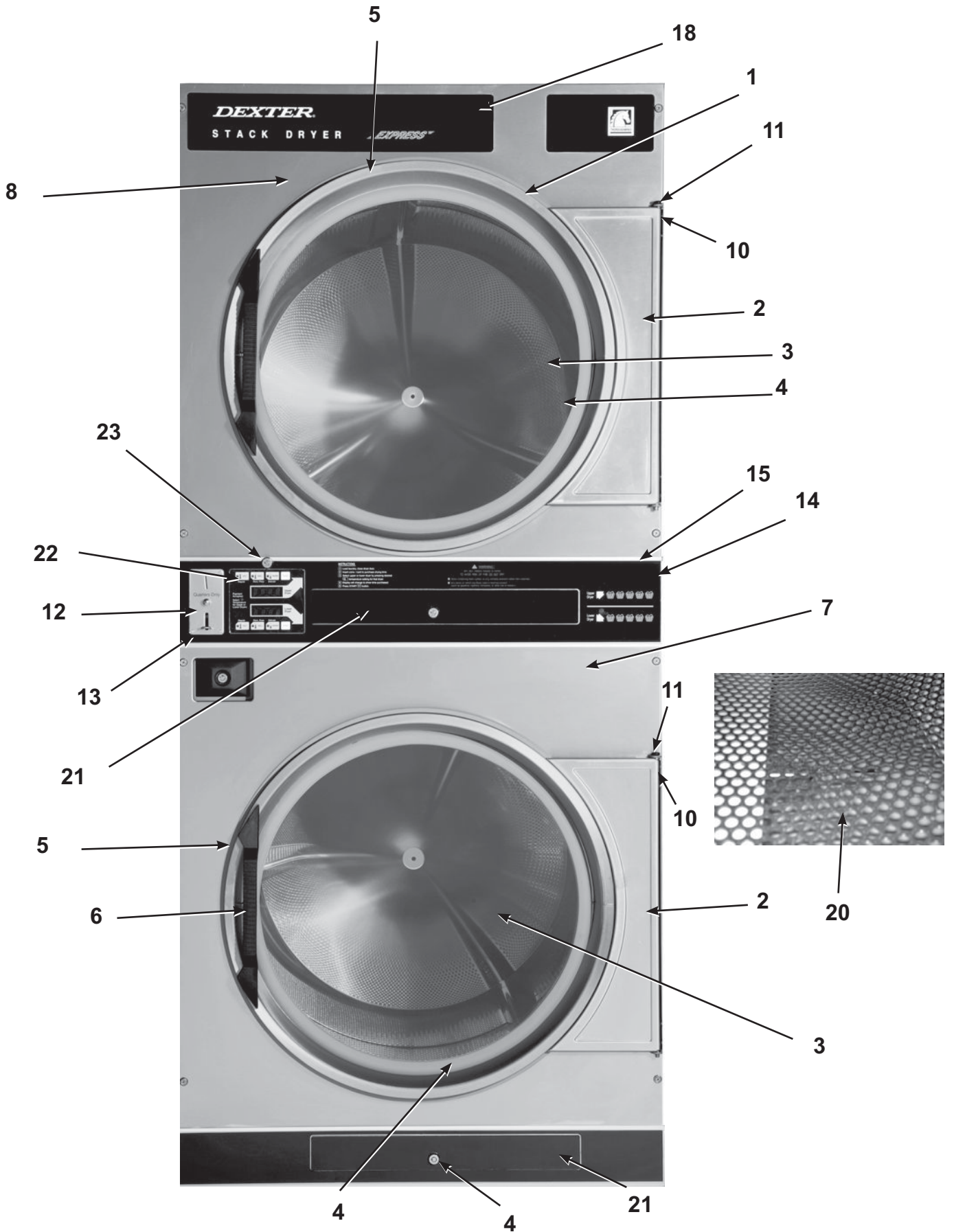

Parts Data

Cabinet Group

Key	Part Number	Description	Quantity
*	9960-285-003	Door Assy., Loading Complete-Alm	2
*	9960-285-002	Door Assy., Loading Complete-Wht	2
*	9960-285-001	Door Assy., Loading Complete-SS	2
1	9960-284-002	Door Assy., Loading-SS(ring only)	2
2	9982-353-003	Plate Assy., Hinge (Alm) No Pin	2
2	9982-353-002	Plate Assy., Hinge (Wht) No Pin	2
2	9982-353-001	Plate Assy., Hinge (SS) No Pin	2
*	9545-012-015	Screw, Hinge to Door	8
*	8640-413-002	Nut, Hinge to Door	8
3	9212-002-004	Glass, Door	2
4	9206-164-010	Gasket, Glass	2
*	9548-117-000	Support, Door Glass	2
5	9206-420-004	Gasket, Outer Rim	2
6	9244-082-001	Handle, Loading Door	2
*	9545-018-017	Screw, Handle 1/4-20 x 3/8	2
*	9531-033-001	Stud, Door Catch	2
*	8640-413-001	Nut, Hex	2
*	8640-413-003	Nut, Acorn	2
*	9086-015-002	Catch, Loading Door	2
*	8638-190-009	Pop Rivet for mtg. catch	4
*	8641-582-006	Lockwasher	4
*	8640-399-001	Spring Nut	6
7	9989-517-008	Panel Assy., Front- Lower (Alm)	1
7	9989-517-007	Panel Assy., Front- Lower (Wht)	1
7	9989-517-005	Panel Assy., Front- Lower (SS)	1
8	9989-517-004	Panel Assy., Front- Upper (Alm)	1
8	9989-517-003	Panel Assy., Front- Upper (Wht)	1
8	9989-517-001	Panel Assy., Front- Upper (SS)	1
*	9277-054-001	Insulation Front Panel, half moon (top)	2
*	9277-054-002	Insulation Front Panel, half moon (bottom)	2
	9545-008-014	Screw, FLHDCR, 10B x 1	14
*	8641-585-001	Lockwasher	6
*	8640-399-001	Nut, Spring	12
10	9544-069-003	Strap, Hinge (Alm)	2
10	9544-069-002	Strap, Hinge (Wht)	2
10	9544-069-004	Strap, Hinge (SS/Gray)	2
*	9545-012-028	Screw, Hinge to Panel	8
11	9545-052-001	Screw, Door to Hinge Strap (Special Black Type)	2
*	8641-436-003	Washer, Fiber	2
12	9021-001-010	Acceptor, Coin	1
*	9486-136-001	Retainer, Coin Acceptor	1
13	9545-053-002	Screw	4
*	9732-126-001	Switch (for coin acceptor with extra actuator)	1

Cabinet Group Continued

Key	Part Number	Description	Quantity
14	9994-032-001	Escutcheon, Upper	1
15	9435-022-001	Trim, Overlay-Upper	1
16	9994-033-001	Escutcheon, Lower	1
17	9435-023-001	Trim, Overlay-Lower	1
*	9545-020-009	Screw	10
18	9412-154-001	Nameplate Stack Dryer Express1
21	9866-005-001	Lint Drawer Assembly	2
21	9435-024-001	Overlay Trim, Lint Drwr-	1
*	9532-074-003	Felt Seal (back of lint screen assembly)	2
*	9805-033-002	Lint Screen Assembly ONLY (no front)	2
*	9555-057-008	Replaceable Lint Screen Only	2
24	8650-012-004	Lock and Key, Lint Drawer	2
*	6292-006-007	Key 6324 only.....	2
*	9095-043-001	Cam, Lock.....	2
*	9545-008-001	Lint Screen Strap Hold Down Screws 10Bx 1/4	32
22	9857-147-001	Controls Assy, Electronic Mounted With Membrane Switch	1
22	9801-059-005	Membrane Switch Assy	1
*	9627-869-001	Harness, Electronic Control1
*	9627-854-001	Harness Coin Sw1
23	8650-012-003	Lock and Key, Control	1
*	9095-041-001	Cam, Lock	1
*	9627-870-001	Harness, Heat Sensor1
*	9277-041-017	Insulation Cabinet Cover1
20	9501-004-003	Sensor Temp Control	2
*	9545-045-005	Screw, Round Head (Mounts sensor; phillips head).....	2
*	9209-037-002	Gromm.et, 3/16 ID	2
*	8544-006-001	Leg, Leveling 1/2"	4
*	9074-320-001	Cover, Cabinet (Top)	1
*	9732-253-001	DDAD Kit for Dryers without Neutral and using 208-240 volt1	
*	9732-102-013	LP Kit for DDAD Dryers	1
*	9732-243-001	Stack Dryer Trunion Puller	1
*	9555-057-010	Replaceable Lint Screen Fine Mesh Only.....	.1
*	9277-054-001	Insulation-Front Panel-Top Half	2
*	9277-054-002	Insulation-Front Panel-Lower Half	2
*	9029-169-001	Bracket for Heat Sensor Mounting (Under Basket).....	2
*	8640-276-002	Wire Nut Connector Grey.....	4
*	9527-007-002	Standoff Wire Saddle	8
*	9544-041-002	Strap - Bead Tie	1

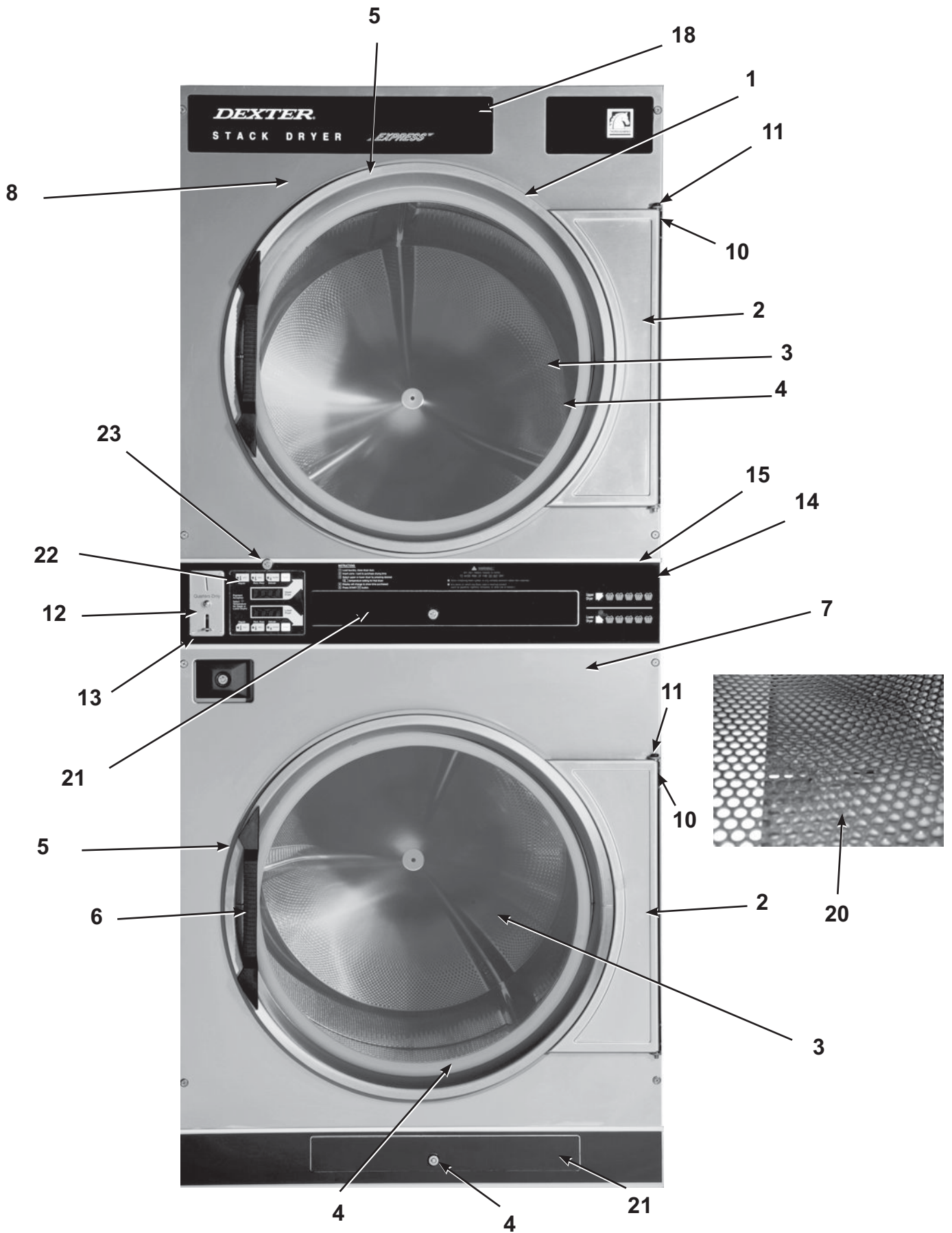

Door Switch Group

Part Number
9539-487-001

Description
Door Switches2

Quantity



Bearing Housing Group

Key	Part Number	Description	Quantity
J1	9241-189-002	Housing, Bearing	2
J2	9036-159-001	Bearing, Ball	4
*	9538-183-001	Spacer, Bearing	2
J5	9545-017-017	Bolt, 1/2 x 3/4	10
J7	8640-417-002	Nut, 1/2	4
*	9803-201-001	Bearing Housing Complete Ass'y (includes bearings,spacer)	2
J4	9545-159-003	Screw 1/2 x 1 1/2.....	4
*	9036-159-003	Bearing Rear	1

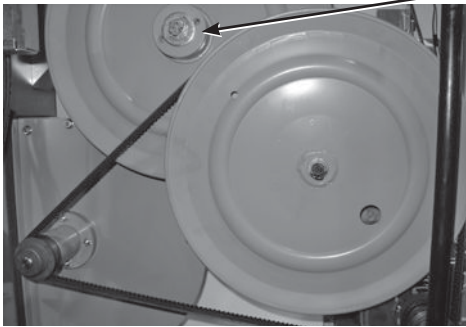

**Torque
150 FT
Pounds**

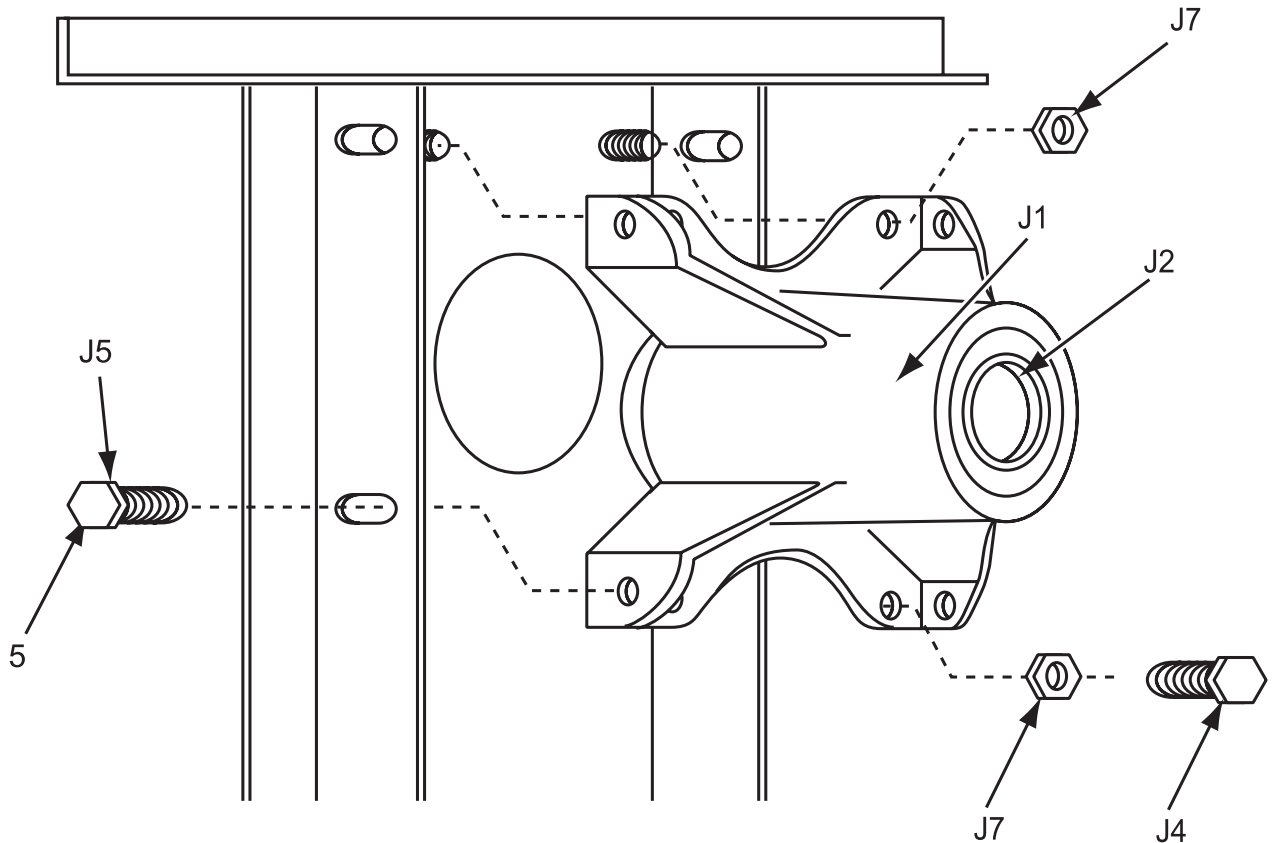
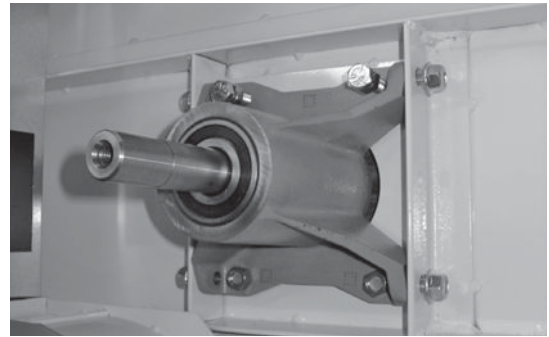

Burner Housing Group

Key	Part Number	Description	Quantity
*	9803-203-001	Housing Assembly, Burner	2
1a	9452-730-001	Service Burner Plate Front... ..	2
1	9452-729-001	Service Plate baffle Recirculation Chamber Clean Out.....	2
*	9545-008-006	Screws	8
2	9545-008-001	Screw	16
18	9003-220-001	Angle, Burner Support	2
*	9545-008-006	Screw	4
17	9048-020-002	Burner, Main	4
*	9545-008-006	Screw 10AB x 3/8"	4
*	9454-806-001	Panel, Back Burner Housing	2
4	9545-008-001	Screw 10B x1/4"	8
5	9875-002-003	Electrode Assy, Ignition	2
19	9545-045-001	Screw, Electrode Mtg 8B x 1/4".....	4
7	9379-186-001	Valve, Gas Shut Off	1
8	9857-134-001	Control Assy, Gas	2
9	9381-009-006	Manifold, Assy	2
*	9425-069-010	Orifice, Burner-Natural #27	4
*	9425-069-024	Orifice, Burner-LP #44	4
10	9029-175-001	Bracket, Manifold	2
14	9039-915-001	Bracket, Gas Control	2
22	8615-104-038	Pipe Plug in end of Burner Manifold	2
11	9452-749-001	Plate Assy, Hi-Limit Stat Ignitor	2
*	9545-008-006	Screw	4
12	9576-203-002	Thermostat, Hi-Limit	2
*	9538-142-001	Spacer, Hi-Limit	4
*	9545-045-007	Screw 8B x 3/4".....	4
13	9074-234-001	Cover, Hi-Limit Stat Ignitor	2
*	9545-008-006	Screw	6
*	9576-207-008	Thermostat, Safety Shutoff	2
*	9545-008-006	Screw	4
15	9825-058-001	Cover, Safety Stat	2
*	9545-008-006	Screw	4
16	9857-116-003	Control, Ignition Fenwall (3 trybox)	2
*	9550-189-001	Shield, Burner Inlet	1
*	9732-102-001	Kit, LP Conversion DDAD Kit	2
*	9838-018-002 ^	Welded One Piece Gas Pipe Assembly (Used After 9/07)	
*	9381-012-001 ^	Manifold Assembly 2 Port One Piece Used After 9/07	

^ Models built before 9/07

Burner Housing Group Photos

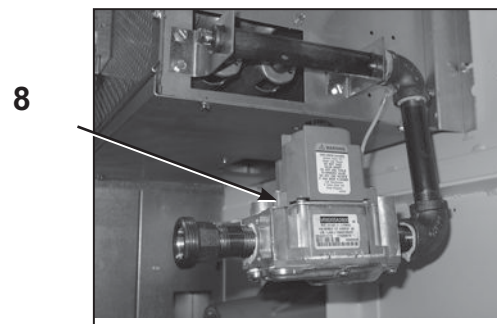
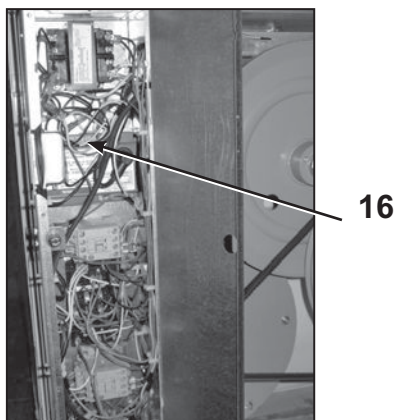
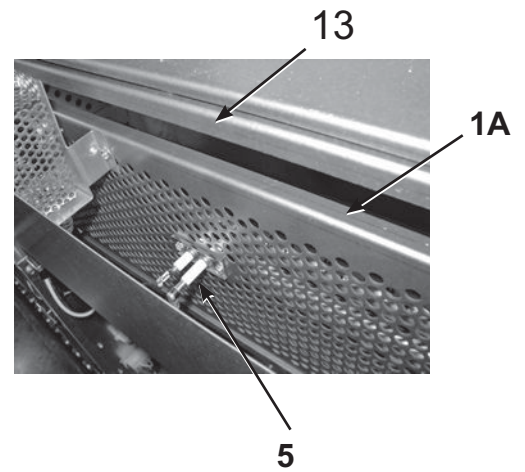
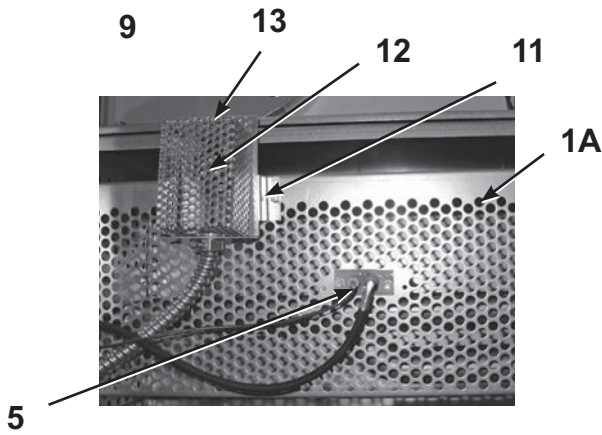
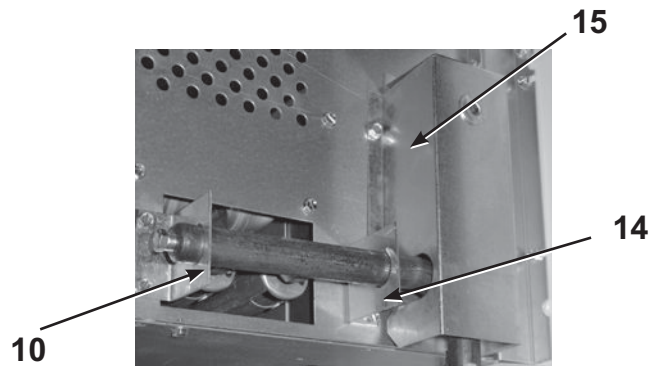
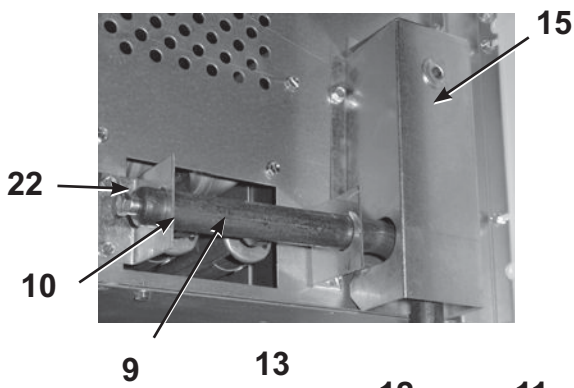
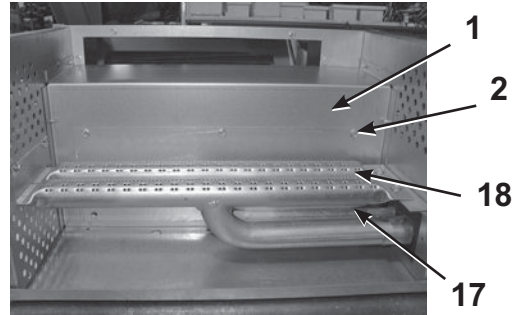
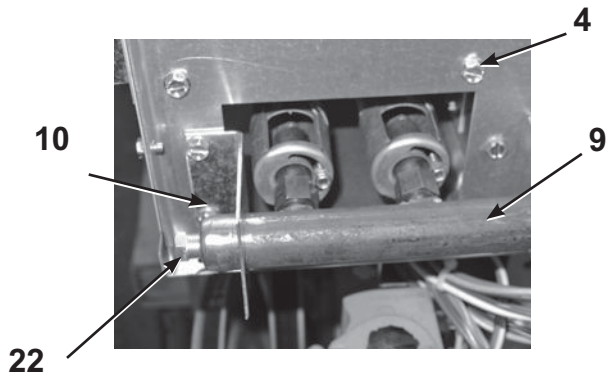

Rear View

Key	Part Number	Description	Quantity
*	9627-875-001	Wire Harness Overtemperature Switch Upper	1
*	9801-095-001	Switch Assy, Air Flow	2
1	9539-461-009	Switch, Air Flow.....	2
2	9029-174-001	Bracket, Switch- Air Flow	2
3	9008-007-001	Actuator, Switch	2
4	9451-169-002	Pin, Cotter	2
5	9545-020-001	Screw 4-40 x 5/8"	4
7	9376-313-001	Motor, Drive	2
8	9452-745-002	Plate, Impeller Mtg	2
9	9537-204-001	Shaft Impeller.....	2
10	9803-204-001	Housing Assembly w/ Bearings for Impeller	2
10	9453-157-001	Pulley - Impeller Drive	1
11	9991-053-001	Support Assy, Intermed. Pulley	2
12	9545-029-010	Bolt, Rd Hd 3/8-16 x 1 1/4	6
12	8640-415-004	Nut Flange Wizlock 3/8" - 16.....	6
12	8641-581-035	Washer, Flat	6
13	9545-029-003	Bolt, 3/8-16 x 1 1/2	2
14	9861-022-001	Arm Assy-Tension, Complete	2
*	9487-200-003	Ring-Retaining	6
16	9908-046-003	Pulley Assy, Intermediate with bronze flange bearing	2
17	9908-040-003	Pulley Driven Tumbler	2
19	9040-076-004	Belt, Drive Impeller and Intermediate Pulley.....	2
20	9040-073-010	Belt, Driven Intermediate to Tumbler	2
21	9534-151-000	Spring, Tension	2
22	9099-012-005	Chain, Tension	2
23	9248-022-002	Hook, Tension	2
*	9451-146-001	Pin, Damper Hinge	2
*	9825-322-001	Cover Duct Upper	1
25	9973-030-001	Heat Recirculation Assembly Duct	2
26	9919-018-011	Impeller Assembly Complete w/ Bearings, Shaft, Plate.....	2
27	9453-157-001	Motor Pulley - Driver	1
28	9545-028-013	Set Screws	2
29	9241-191-002	Bearing Housing Only Impeller	2
30	9278-038-004	Impeller	2
*	9036-159-010	Ball Bearing for Above Impeller Shaft.....	4
*	9487-200-007	Ring-Retaining External for Impeller Bearing Housing	4
*	9545-018-009	Screw, 1/4-20 x 1 Impeller Bearing Housing.....	4
34	8641-581-026	Washer, Flat 1/2" for Tumbler Pulley	2
35	9545-017-009	Bolt, 1/2"-13 x 1 1/4	2
36	8641-582-016	Washer, Star 1/2" for Tumbler Pulley	2
*	8640-401-001	Nut, Special Twin #4-40.....	2
*	9550-169-003	Shield, Switch	2
*	9545-008-001	Screw 10 Bx 1/4"	6
*	9545-014-004	Bolt, 5/16-18 x 5/8"	8
*	8640-400-003	Nut, 5/16-18.....	8
*	9036-145-002	Bearing - Bronze Flange	4
*	9538-164-001	Spacer, Shaft	2
*	9487-234-005	Ring Tolerance.....	2
*	9125-006-001	Damper Inside Duct Exhaust	2
*	8520-141-000	Nut, Spring	4
*	9545-008-026	Screw #10B x 1/2"	14
*	9074-323-001	Cover Duct Lower	1
*	9545-008-024	Screw 10ABx 3/8"	58
*	9029-173-001	Bracket for Wire Harness Under Burner Housing.....	2

Rear View Photos

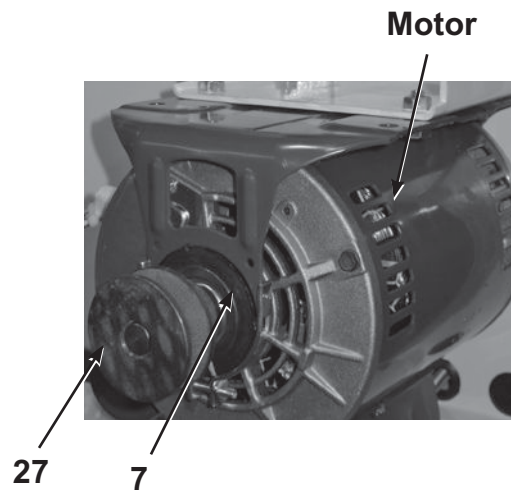
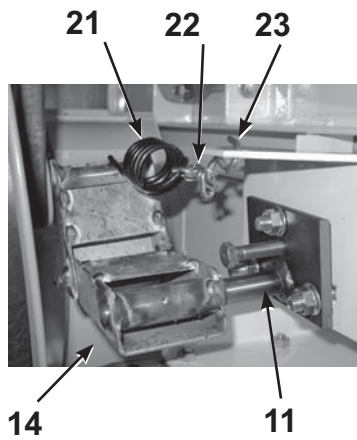
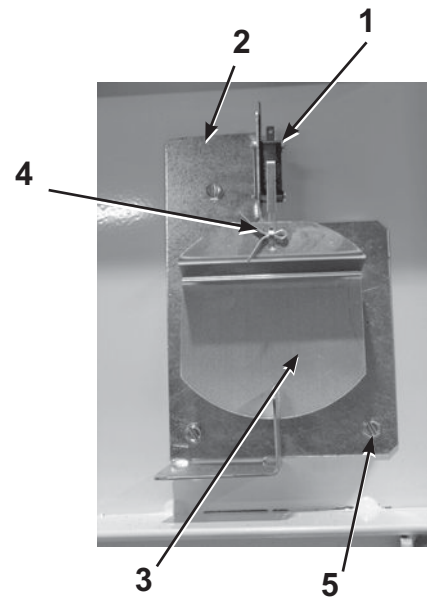
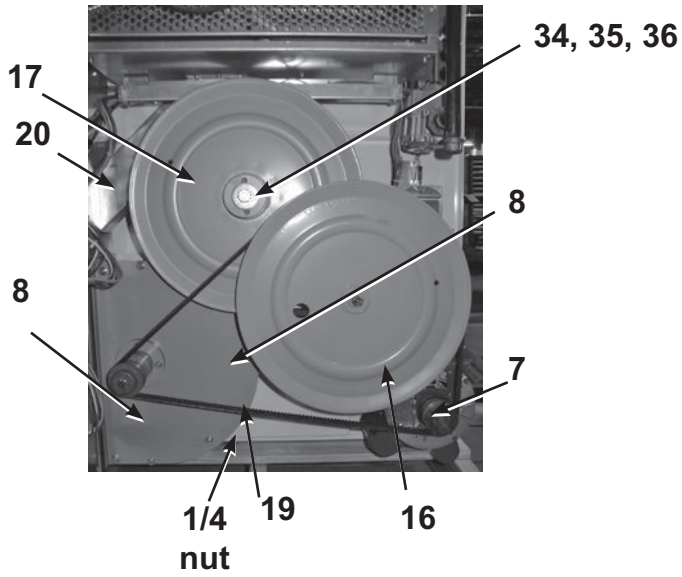
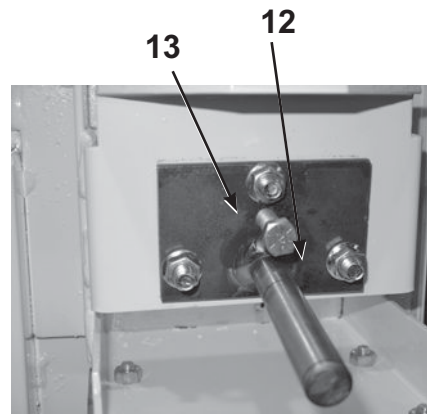
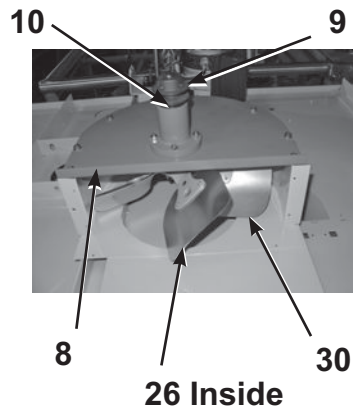
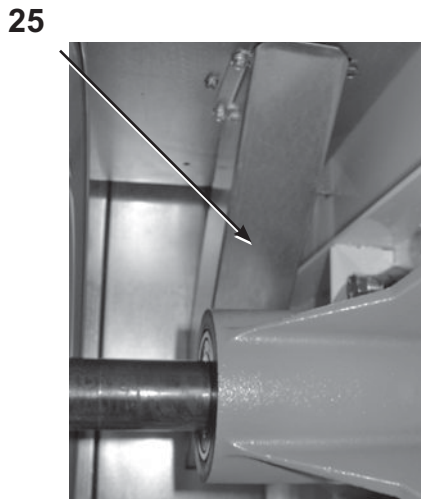

Rear Panel & Cover Group

Key	Part Number	Description	Quantity
1	9208-078-001	Rear Guard Side Panel 1	2
2	9208-079-001	Rear Guard Top Upper.....	1
*	9074-325-001	Power Main Input Cover	1
4	9545-008-006	Screws 10 AB x 3/8.....	30
5	8502-649-001	Label - Connection Electrical	1
*	9208-082-001	Rear Guard Top, Lower.....	1
7	9208-082-024	Screws 10 AB x 3/8.....	6
8	9208-081-001	Rear Guard Back Panel	2
9	9059-065-001	Band - Edge, Plastic Spring	1
10	8502-600-001	Label Warning & Notice	1
11	8502-645-001	Label - Instructions.....	1
12	9791-002-001	Transition Assembly Outlet	1
13	9074-320-001	Top Cover Dryer Panel.....	1
14	9074-321-001	Top Panel Burner Housing Cover	1
15	9550-189-001	Top Burner Housing Heat Shield	1
16	9208-077-001	Wire Guard Upper, Lower Keeps Against Duct Housing	2

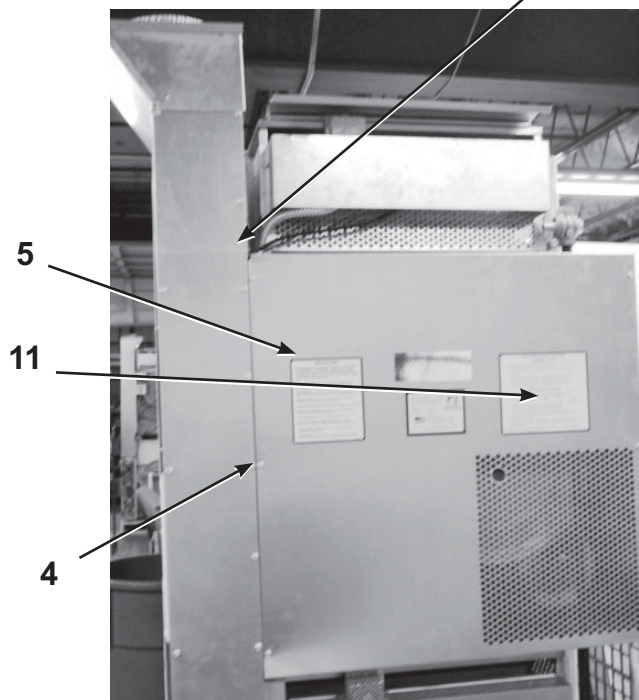
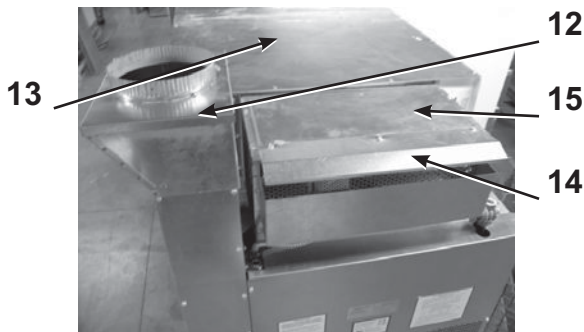
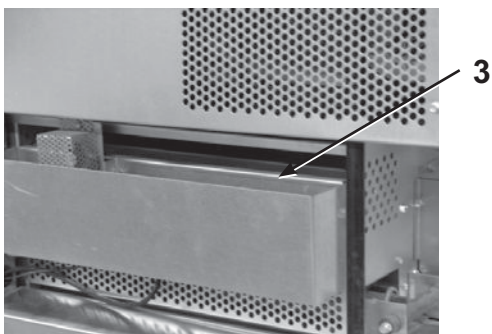
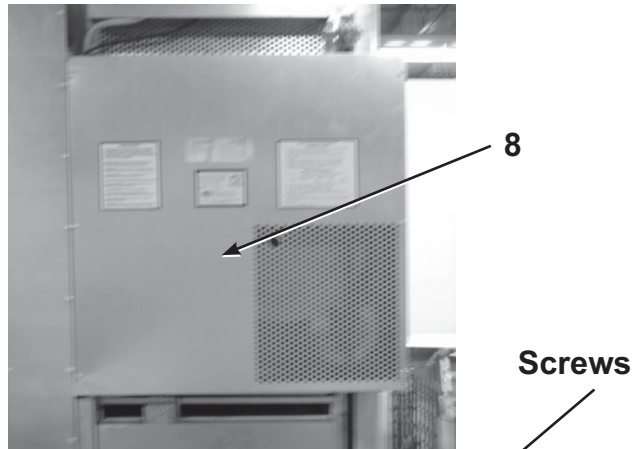
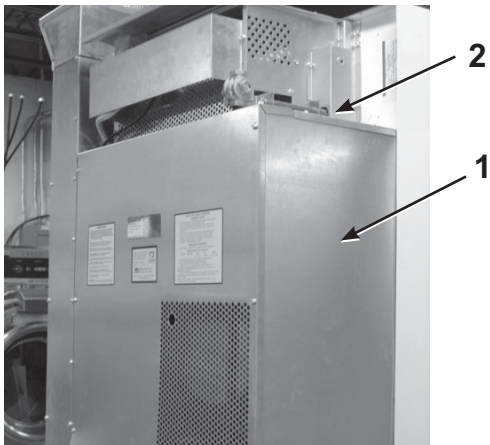

Tumbler Group

Key	Part Number	Description	Quantity
	9848-131-001	Tumbler Assembly Galvanized w/spider	2
G2	9568-013-001	Spider Assembly	2
G3	9497-226-002	Rod, Tumbler	6
G4	8640-417-005	Nut, 1/2 - 13.....	6
G6	8641-590-002	Washer, Special	6
G7	9552-013-000	Shim	AR
*	9848-130-002	Tumbler Assembly Stainless Steel.....	2
G1	9848-130-001	Tumber Assembly Galvanized	2

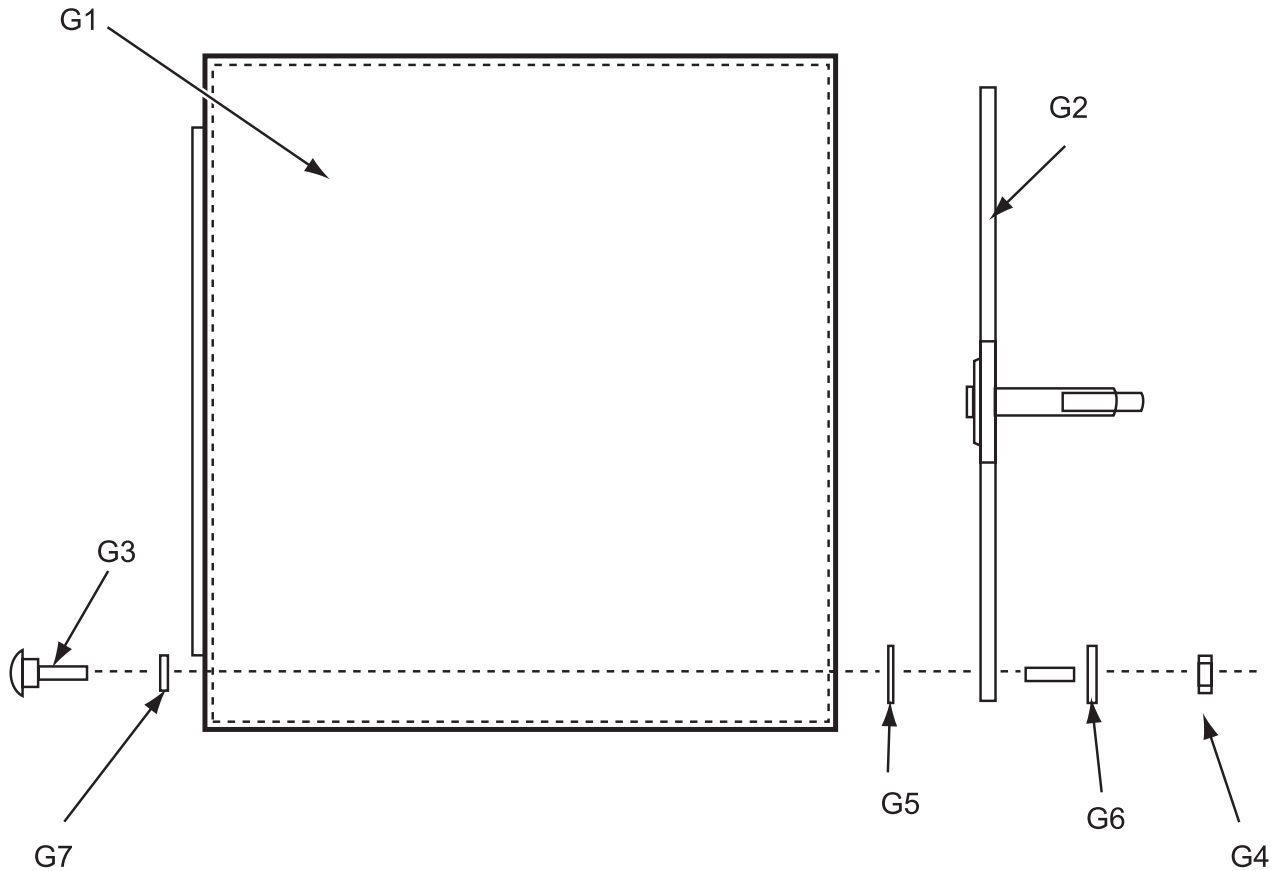

Control Assembly Group

Key	Part Number	Description	Quantity
*	9857-173-001	Control Assmbly Complete (all below included)	1
*	9074-324-001	Control Box Cover	1
*	8220-001-478	Wire Assembly Green 7"	1
*	8639-621-007	Screw #10-32 x 12 Green.....	1
*	8641-582-006	Lockwasher Ext Tooth #10	1
3	9897-026-002	Terminal Block Main Power Middle	1
4	9897-026-001	Terminal Block	2
*	9545-045-012	Screw #8 ABx 1/2 for terminal block	4
5	8711-011-001	Transformer Ignition.....	2
*	9545-008-024	Screws 10AB x 3/8"	4
6	9982-355-001	Plate Assembly MTG Ignition Control.....	2
*	9545-008-001	Screws 10B x 1/4" MTG Above Plate and Others.....	13
7	9857-116-003	Ignition Control	2
*	8640-411-003	#6-32 Nuts.....	4
8	9631-403-011	Wire Assembly High Voltage Upper	2
9	9627-873-001	Wire Harness Ignition Control Upper.....	1
10	9627-873-002	Wire Harness Ignition Control Lower.....	1
*	9053-067-002	Bushing Wire 7/8"	4
13	9200-001-002	Fuseholder Assembly	2
14	8636-018-001	Fuse 1.5 Amp.....	2
15	5192-295-016	Relay Power.....	2
16	9897-036-001	Terminal Block Assembly Main Power Inlet.....	1
*	9545-045-012	Screw #8 AB x 1/2"	3
*	8220-062-036	Wire Assembly Red/Black 14"	1
*	8220-062-037	Wire Assembly Red/White 14".....	1
*	8220-062-038	Wire Assembly White 14"	2
*	9627-868-001	Wire Harness - Power Main Input.....	1
21	9627-874-001	Wire Harness Motor Extension.....	2
*	9527-007-001	Stand Off - Wire Saddle / Arrowhead	15
*	9545-031-005	Screw 6 B x 3/8"	4
22	9558-031-001	Strip Terminal Marker (Behind Input Power) to above #3.....	1
*	9627-863-001	Wire Harness Main Extension Access Under Burner Housing	1
23	9631-403-013	Wire Ass'y - High Voltage Lower	1
24	9029-048-001	Bracket - Fuseholder	2
25	9627-859-001	Wire Harness - Main Power.....	1

Control Assembly Group

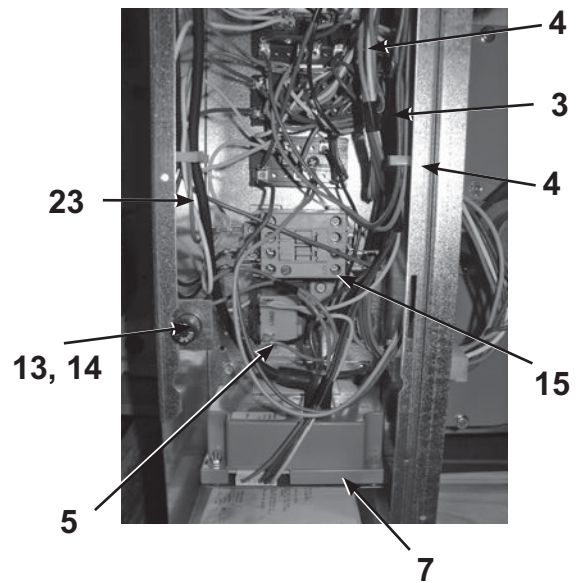
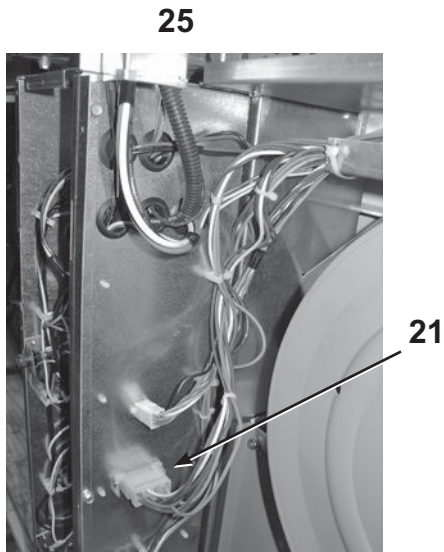
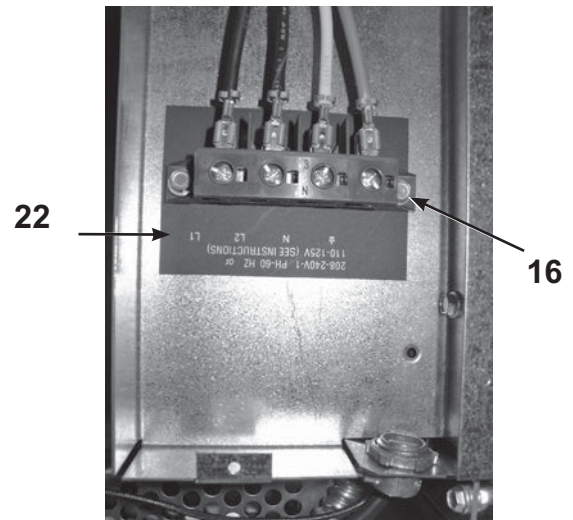
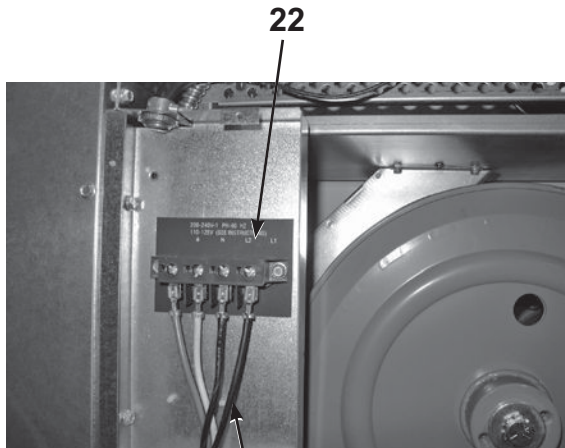
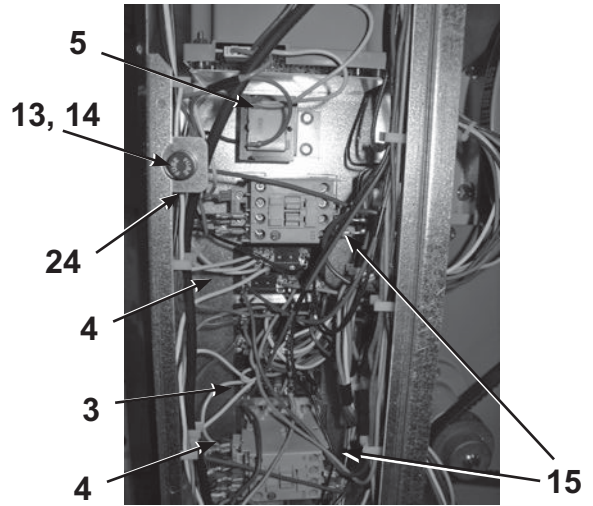
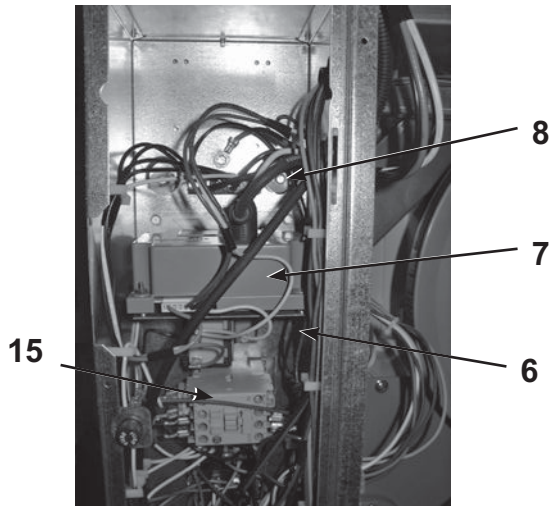

Coin Handling Group

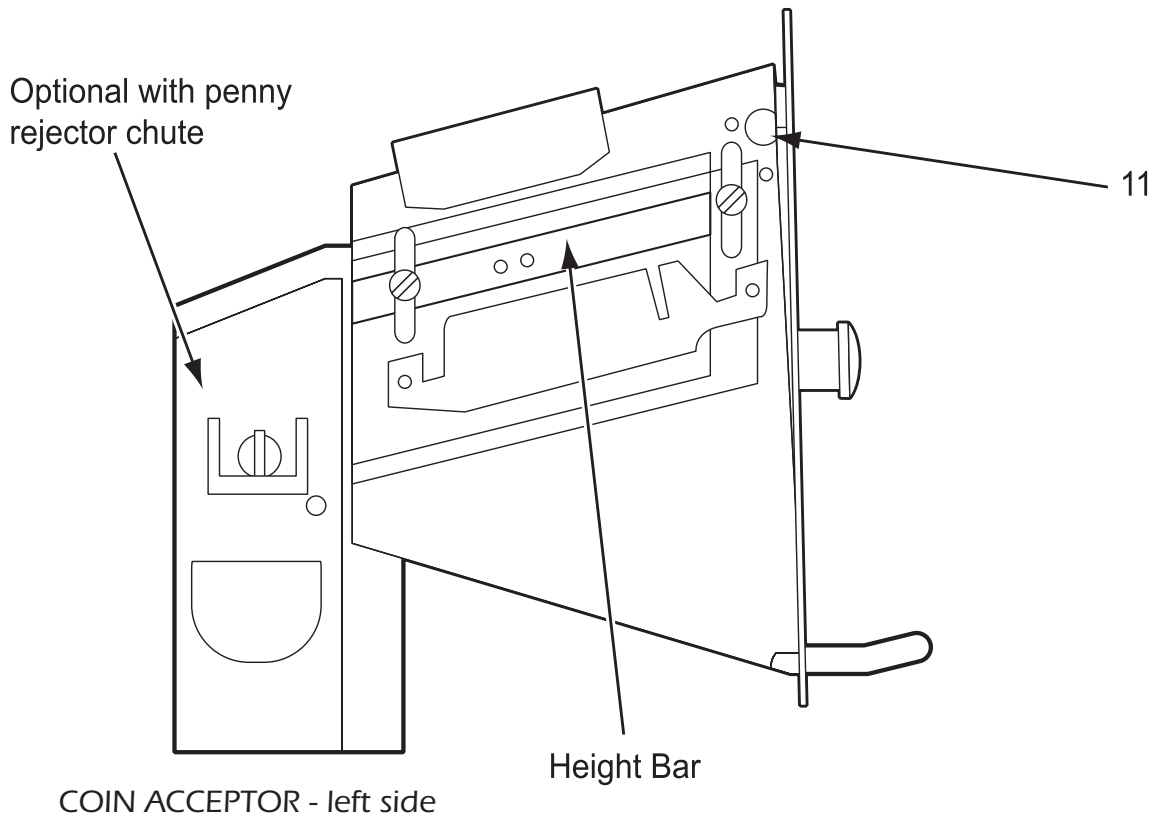
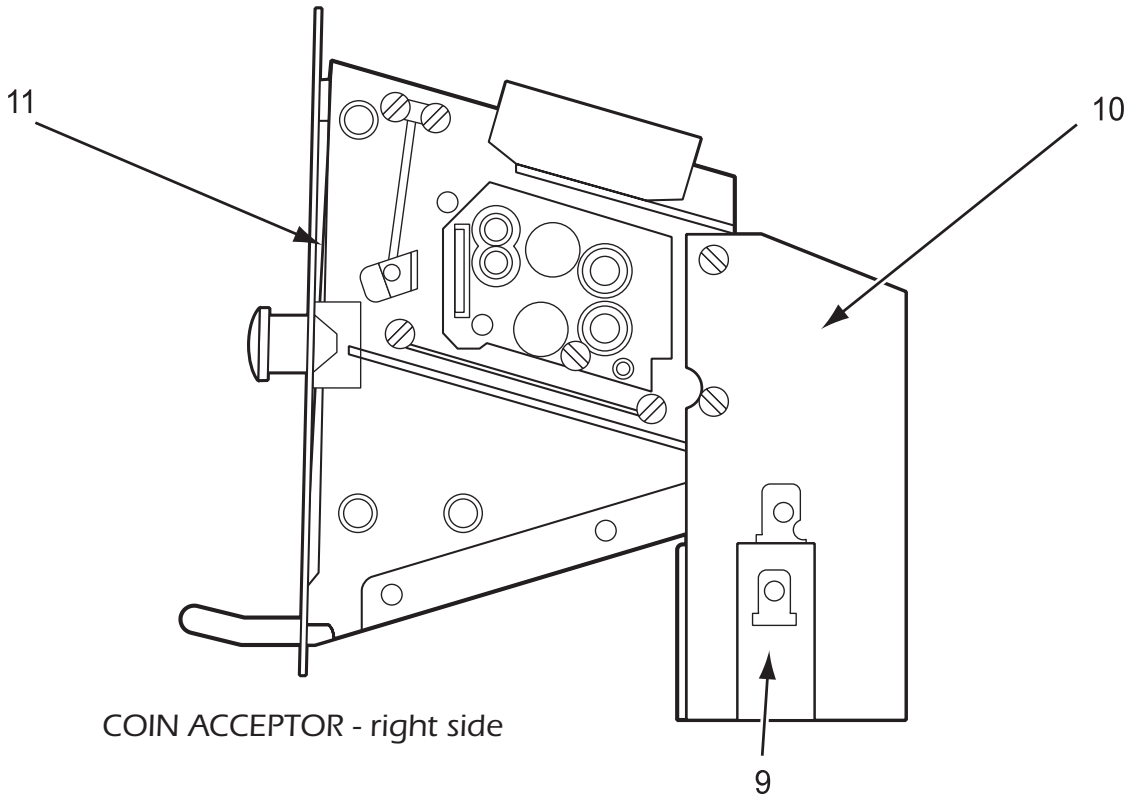

Section 7:

Voltage Conversion

Instructions - Convert a Dual Voltage Stack Dryer from 120V to 208-240V with Neutral Wire Only

1. Remove incoming power from the dryer. Use a known working voltmeter to check power.
2. Remove the cover of the control box assembly from the dryer using a 5/16" wrench.
3. Move the black/blue wire from the N position of the main power terminal block to the L2 position of the main power terminal block in the control box assembly.
4. Move the white wire of the upper motor harness to an upper inner left terminal in the middle terminal block in the control box assembly. See Figure 1 below.
5. Move the orange wire of the upper motor harness to an upper inner left terminal in the middle terminal block control box assembly. See Figure 1 below.
6. Move the white wire of the lower motor harness to a lower inner left terminal in the middle terminal block in the control box assembly. See Figure 1 below.
7. Move the orange wire of the lower motor harness to a lower inner left terminal in the middle terminal block control box assembly. See Figure 1 below.
8. Reconnect power to the dryer and test to ensure proper operation; one line voltage to L1, one line voltage to L2, the neutral to N, and the earth ground to E.
9. Reinstall the cover of the control box assembly from the dryer using a 5/16" wrench.

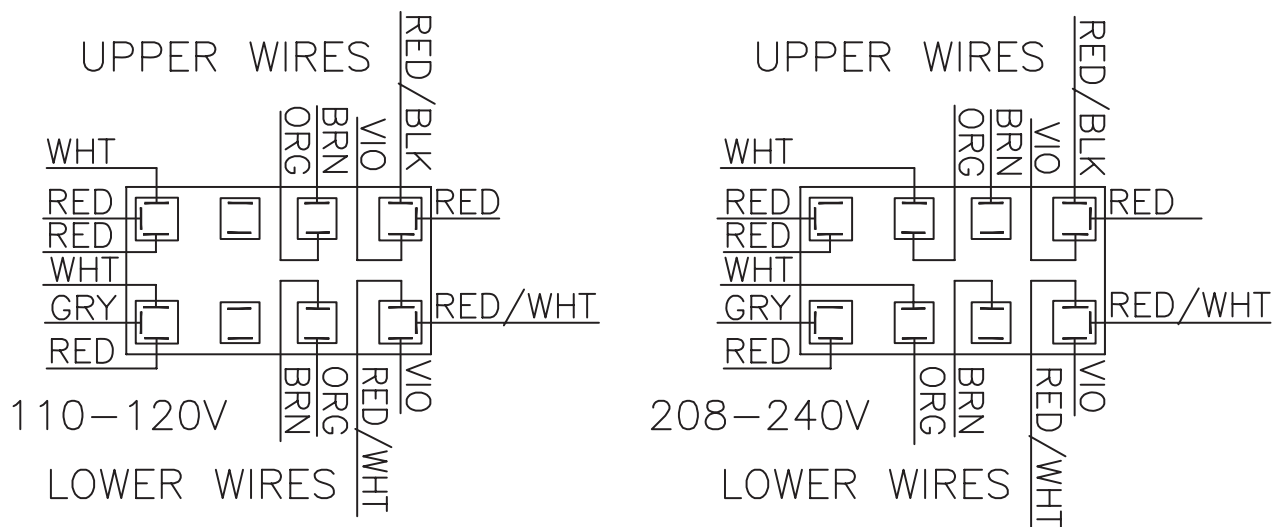
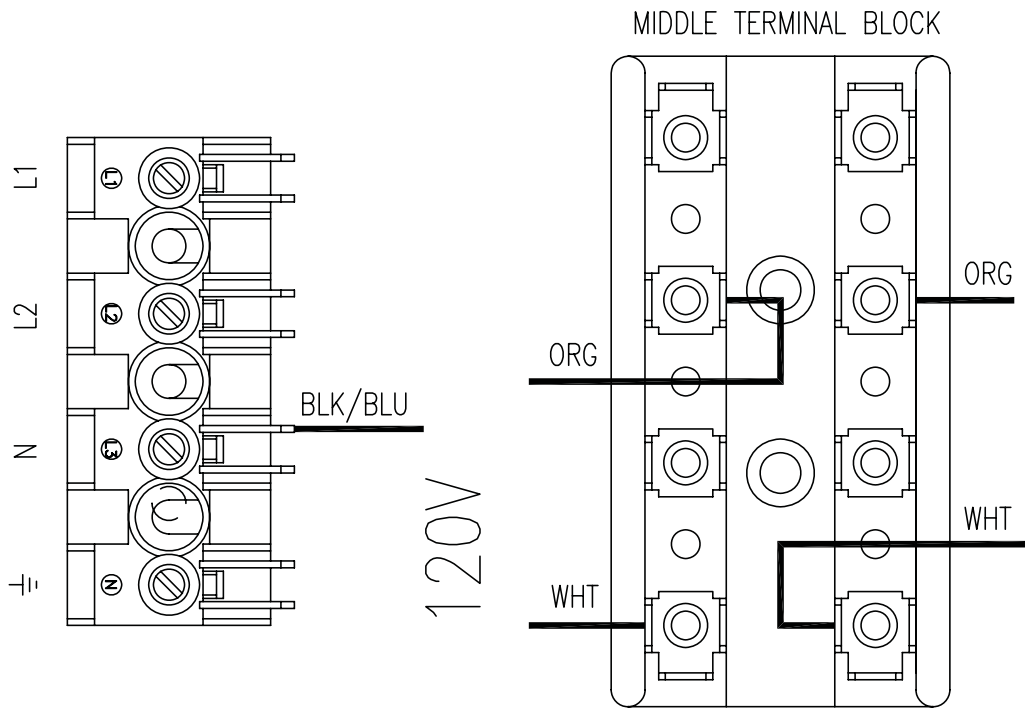
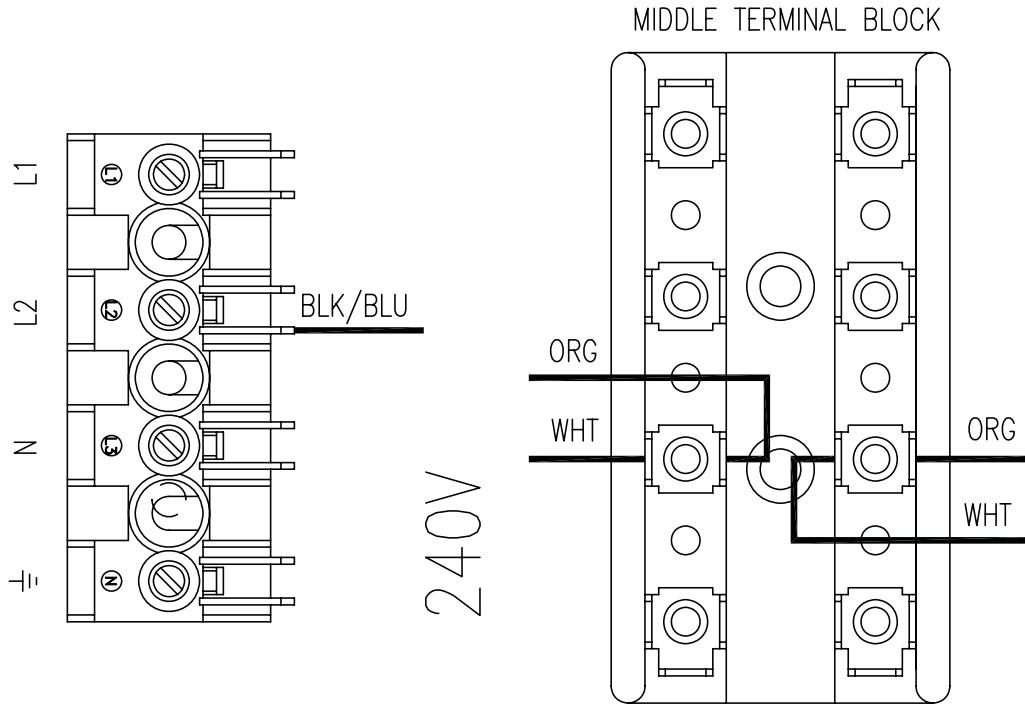

Figure 1 Middle Terminal Block



DUAL VOLTAGE STACK DRYER VOLTAGE CONVERSION